



NATSKA
NATIONAL SCHOOLS KARTING ASSOCIATION





CONTENTS:

<u>Page:</u>	Title:
3	Welcome
4	Retiring Drivers 2021
10	History of Schools Karting
17	Race Report: Fulbeck 10th April
19	Race Report: Whilton Mill 3rd May
21	Race Report: Shenington 8th May
23	Race Report: Camberley 29th May
26	Race Report: Fulbeck 12th June
29	Race Report: Bayford Meadow 27th June
32	The "BSB" Group
33	Championship Tables - As they stand
36	The Last Word: A tribute





So...what can we say about the 2020-21 season?

It's been memorable! So here's a little "snapshot" of the year...

We said "Goodbye" to Stuart in the Chairman role - a position that he has held for 5 yearsbut he isn't going far, and you can now see him on the grid in an even more relaxed mode (and of course he is still around to offer his advice and words of wisdom). We all offer our sincere thanks for his time and dedication to our organisation and for steering us through some very difficult times.

This year we have had more meetings than we managed during 2019-20 (9 including the Nationals in 2020-21 compared to just 5 in the previous year)...the calendar has twisted and turned as we have tried to beat Covid and comply with lots of government regulations...Bayford Meadow in March moved to June, and our March Whilton Mill meeting became a Bank Holiday Monday in May (it's just a shame no-one told the weather!).

...we had to say goodbye to meetings at Clay Pigeon and Llandow (as overnight stays were not permitted)...and our Nationals meeting at GYG had to be rearranged (as a result of Welsh government restrictions which meant planning for the event was impossible - and even up to 6 weeks before the event the restrictions were such that we simply could not have had a meeting)...but our friends at Fulbeck were able to fit us into their calendar and we have now visited for four of our nine rounds of the championship.

We have been very lucky that, for the most part, our drivers and families have escaped from Covid isolation requirements - and I absolutely KNOW that you have all been desperate to get racing again since the re-start at Fulbeck in early April.

Our fantastic Covid Officer, Val (ably assisted by Steve Keirle and Toni Hammond) has got us through some very tough government restrictions and we have been able to carry on racing...something we quite simply could not have done without Val's efforts - I know that it has been a thankless task for her, but our reputation with Motorsport UK and all of the Stewards who have visited us is second to none. So let us take

this opportunity here, in print, to record our huge thanks to Val for "keeping us on track"

Our race meetings don't "just happen"...and we want to thank every single person who volunteers their time to NatSKA in order to let you all come racing....

This year we have celebrated the fact that we made it on to the pages of Motorsport UK's "Revolution" magazine in advance of the April Fulbeck meeting (page 60 of the March edition!)...and subsequently one of NatSKA's own, Maria Bright, became a "feature star" when they did an article on Volunteers in Motorsport (check her out on page 42 of the April 2021 edition)!...and we are hoping that we get a write up celebrating our 50th Anniversary in the August / September editions...

One of our "old boys" Joseph Loake is celebrating being chosen to be a member of Motorsport UK's Academy "Class of 2021" which equips the UK's most promising young drivers with the knowledge, skills and attitude needed to maximise their performance.

Another of our alumni, Tom Oliphant, continues to race hard in the British Touring Car Championship and is hoping to build on last year where he took to the top spot of the podium!

...and so to the Nationals, and our celebration of the 50th Anniversary of NatSKA....sadly curtailed by ongoing Covid restrictions...a few of the things that we had planned simply cannot take place, but hopefully you will all have a fantastic weekend...and even though your families cannot come to the event to watch you in person, they will be able to see you "on the telly" via the Alpha Live streaming programme. You find us via these links: Saturday: https://youtu.be/JTTLELg_CYM Sunday: https://youtu.be/USdaw_UjkhY (and also on their facebook page). Special thanks to NatSKA "old boy" Jack Oliphant who is coming to do the commentary!

So... the culmination of our season...we hope that you all HAVE FUN, are the best that you can be, and at the end of the weekend go home smiling!



RETIRING DRIVERS 2021

So...we asked every retiring driver:

b) details of what their proudest NatSKA moment was;

c) what they are going on to do now (be that in education terms, or racing!);

d) a key learning point from karting that they would have told their younger novice self

This is what they all said: "directly quoted!"

DAN JONES (AMS - Class 15 Kart 1)



Dan's proudest NatSKA moment was: The first ever race day with NATSKA at Camberley in the cadet novice class and being awarded novice of the day (pictured above).

After NatSKA, Dan is going to: do a Motor Sport Engineering Degree and hopes to join a professional race team when I have completed university as an engineer. I will continue to race as much as my university work load will allow and hope to compete in a national championship next year. Both my Dad and myself will also still attend as many NATSKA race days as possible to support Chris Brown the Team Leader of AMS & all the AMS young drivers along with NATSKA.

Dan's key learning point from karting that he would have told his younger novice self. To never stop believing in yourself, my strength has been the taking part in a great sport and walking away at the end of each race day with a smile on my face knowing winning or losing I have given it my best. (My Dad explains it as character building!)

Dan would like to share the following... I would like to say to any families with a young driver that wants to start Karting to get in touch with NATSKA, go along to one of their race meetings and see how it all works. My Dad made the decision to join NATSKA to give me the chance to compete and learn about racing in a safe, controlled, race with respect and structured environment, where they put the young drivers first every time. The family environment is so special with everyone helping each other and I can't thank NATSKA enough for the wonderful times both myself and my family have enjoyed being a part of NATSKA.

LEO CRABTREE

(St Michael's - Class 7 Kart 1)



Leo's proudest NatSKA moments were:

- First trophy in Class 11 Novice at Camberley in March 2015 (picture above)
- Runner up in Class 11 championship in 2015-2016 season and finishing 3rd in Nationals at Clay Pigeon in the same season.





WINNING DRIVERS 2022

- Winning my first race meeting in Class 7 - Clay Pigeon June 2019 - celebrating with class 7 team mates Nathan Howard & Rowan Mackley



- Winning Class 7 championship in 2019-2020 alongside David Hull (Team Leader) recipient of Graham Keyte Trophy in the same year.



After NatSKA, Leo is going to:

In terms of racing, I am competing in the National Kart Cup (NKC), Senior TKM. I finished in 3rd place at the last NKC round held at Lydd and thoroughly enjoyed the large competitive grid, close racing with some very experienced drivers. I firmly believe that my time with NatSKA has been a valuable learning experience and foundation enabling me to enter senior events and be competitive immediately. I also plan to enter Senior TKM in club meetings at Kimbolton, time permitting, later in the year. Unsure as to the future, however, I plan to continue racing in the short term whilst enjoying the sport.

Having successfully completed at BTEC in Engineering (Level 3) at Runshaw College, Leyland, I am seeking an Engineering Apprenticeship, ideally a degree Apprenticeship and await feedback from a number of companies following recent apprenticeship applications and interviews.

Until I secure a full time job, or apprenticeship, I will continue with my various part time jobs:- Waiter in a local restaurant, takeaway delivery driver and church cleaner..!!

Leo's key learning point from karting that he would have told his younger novice self.

My advice to all novice drivers is:

- Never give up - keep trying, improve your driving & learning kart preparation skills
- Stay positive - through the many highs & Lows of karting
- Bounce back from significant set-backs - whether injury, kart damage, poor result, etc
- Listen and implement advice from more senior drivers and Team Leaders
- Celebrate your achievements with your team, whether it be a heat win, race meeting win, championship win or simply beating a team mate or another competitor in your class..!!

HENRY WARDELL (BEXLEY - Class 7 Kart 1)





RETIRING DRIVERS 2022

Henry's proudest NatSKA moment was:

Winning a Rotax meeting at Whilton Mill (or any first!)

After NatSKA, Henry is going to: Do Mechanical Engineering at University.

Henry's key learning point from karting that he would have told his younger novice self.

Don't focus on results, focus on having fun!

RYAN NEVE (BEXLEY - Class 15 Kart 2)



Ryan's proudest NatSKA moment was:

Winning at Buckmore my local track



After NatSKA, Ryan is going to: Grades permitting going to Coventry Uni to study degree in Motorsports Engineering

Ryan's key learning point from karting that he would have told his younger novice self. Concentrate on your team mates, supporting your friends, being your best self at racing and ignore the politics of it all

Ryan would like to share the following... Special thanks to all @ Natska that have given me fun memories, races, BBQ's and socials to look back on, the volunteers, support of my team mates and family and finally Mum and Dad for all the support, travelling, time and patience.

JAMES HABERSHON (BARCLAY - Class 15 Kart 33)



James started in Class 11 in 2015, when in year 7. He won the Sprint at the Nationals in Rowrah at the end of his first season which was probably one of his proudest moments. The following year he won the Sprint and the Championship in Class 11 before moving into Class 15.

He currently has no plans to continue racing, although is contemplating a move to MSA or IKR. He is currently enjoying life working as a labourer with a great mentor and enjoying being an 18 year old with the pubs open!



RETIRED DRIVERS 2022

JULIAN SANDERS

(Thomas Alleyne Academy - Class 8 Kart 51)



Julian's proudest NatSKA moment was: This would have to be moving up to a high power class from the Honda, and getting straight up to speed. The jump was so big and was a real challenge; you almost have to learn to race all over again. I like to think I did an amazing job though and the pace came very quick.

After NatSKA, Julian is going to: I'm exploring the possibility of racing in another championship after gaining some sponsorship and lots of valuable knowledge from my time in NatSKA and will hopefully have a plan together soon.

Julian's key learning point from karting that he would have told his younger novice self. This is a tough one as I've learnt a huge array of skills, along with how dangerous but fun racing can be. I think the most valuable bit of advice I could give is to take care of yourself, drive your own race and be patient as the results will come if you are driving at your peak.

Julian would like to share the following... I'd like to use this opportunity to thank everyone in the paddock. No matter what the role is, none of this would have been possible without every single one of you. In particular I'd like to give a big thanks to one of my team leaders, Robin Kingham. In

addition to being a team leader he also plays a role in scrutineering and has coached me throughout my time in NatSKA. He's taught me pretty much everything I know about racing and I wouldn't be in the position I am now without his help and expertise. Many thanks and good luck to everyone.

SAMUEL FORBES

(Barnwell- Class 8 Kart 52)



Sam's proudest NatSKA moment was: I'm not sure if I can pick a single proudest moment for myself in NatSKA, for me there have been many 'I can't believe I just did that' moments. If I had to pick though it would probably be one of the race meets I attended to help and not to race. In October 2020 we had a class 12 club engine fail to complete heat 1 and 2 due to two faulty fuel pumps but it then seized in heat 3 and with no replacement at the track, the driver had lost all hope and thought his day was over... but I managed to find enough spare components to fit an old engine block and spare engine parts I had in the van from when I used to race Honda. Before the final race there was a running engine on the drivers kart, with a bit of positive coaching he then went ahead to come second out of 11 after starting the race in last place... But also setting the best and most consistent lap times, catching up to the leader and crossing the finish line just 0.2 seconds behind them! This made his day and more importantly rebuilt his confidence in karting and this was a very big personal win to me. So



RETRO RACERS 2021

long as everyone I help is having a good day I take that home as a personal win. I'm not in it to win it, my win is making sure everyone in my team make it round the track with some good results and then to see drivers come in from the track with the same smile that I used to makes it worth the effort. Even if a driver isn't having a great day I try my best to keep a positive attitude in their head and make sure they don't give up.

After NatSKA, Sam is going to:



I have already started a new ish (to me) race series, Retro Racer. As quite a few of you know I started collecting historic racing gear, karts and engines from the 70's 80's and 90's. little did I know that it would leave me running my own small engine rebuilding/tuning and restoration business. A few of my friends know that I was a bit 4 stroke mad, and I had done everything physically possible to a gx160 - I even turbocharged one! (Which did work, surprisingly) so I thought it was time for a change... with some persuasion from a few friends I went out and bought some 100cc gear, although it wasn't the TKM BT82 I was instructed to buy - I came home with a rotary valve screamer from the late 1980s as I wanted something interesting to bring back class 8. After my first outing at Hooton in 2019 I was obsessed with the sound and acceleration of this thing I had just bought... even though I can't remember finishing a single heat (my own fault for having a lead right foot). But that's enough of that...

Since then thought it would be a good idea to buy a further few (too many) engines and to go along side, too many historic karts too.

Throughout 2020 (after restoring a few karts and engines) I participated in some historic races in various classes ranging from the 70s to the 90s then in the autumn I had a go at two stroke tuning on an engine I had sitting about and wanted to use in the final retro racer event of 2020, Redlodge.

So it turned out I was pretty good at it (lets hope I don't jinx myself) a friend of mine now has this engine and has won multiple races on it and thrashing it all the way to 19,000RPM and it's still going strong! This was a great thing for me as it put a new name on the table for engine preparation in the historic karting scene... I am now tuning, rebuilding and restoring engines for a few people with a good rate of success.

Enough of the boring story now - this is about NatSKA.



Sam's key learning point from karting that he would have told his younger novice self.

A key learning point I would've told my younger self is to have more faith in myself and what I do. I always had doubts about myself but as time has gone on I've realized there is no need for it. I would tell my younger self that what I do works for me and that's what counts.

Never give up.





SIGNAGE MEDIA UK



No1 Supplier of **TRACKSIDE SIGNAGE**

- **Signs**
- **Cnc Cutting**
- **Printing**
- **Banners**

www.signageandmedia.co.uk

Tel: 01959 532826 Email: info@signageandmedia.co.uk

HISTORY OF SCHOOLS KARTING

In 1962 Jim McGregor (Northumberland) made the first school built "Kart" and generated interest from other Craft teachers.

Phil Darby, an advisor for craft education, met a pocket of keen teachers and developed a more organised and safer organisation.

Northumberland held their first "meeting" at Bulmer airfield. Phil Darby and teachers set up Northumberland School Karting Association. Racing was not possible (due to county insurance) so meetings were "Group Practices".

This was 1968 and there were about 16 schools involved.

In 1969 Phil Darby moved to Hertfordshire as the Advisor for Design and Technology. A group of keen teachers started to build karts, and the Herts Schools Karting Association was born and karting was promoted as an extra-curricular activity funded by Phil Darby and Herts Education.

In 1971 at Offley Place in Hertfordshire teachers from Northumberland, Hampshire, Essex, Yorkshire, Lincolnshire and Hertfordshire met for a weekend "conference" and formed NatSKA.

Here is a scan of the minutes of the first ever NatSKA meeting (non-race!)

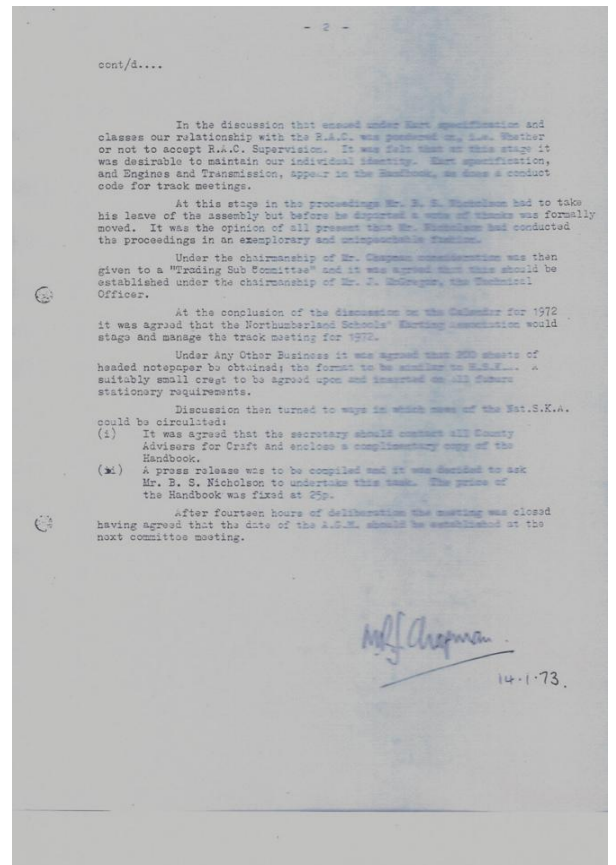
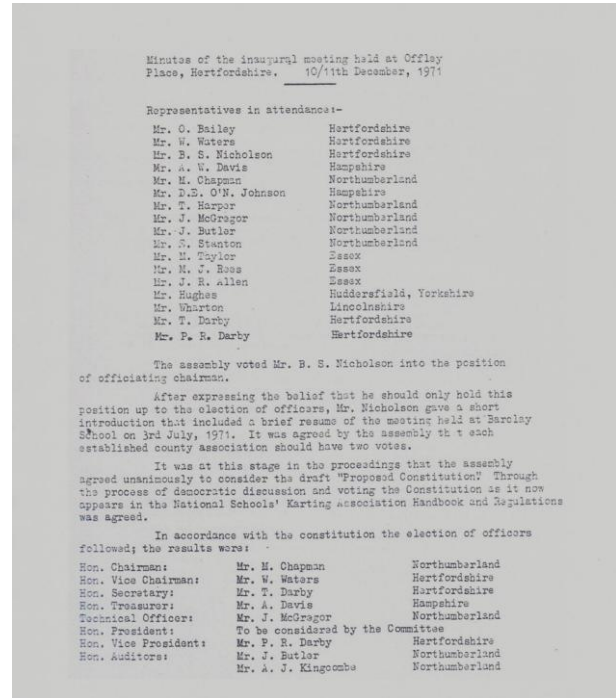

As popularity grew race meetings became larger and the annual National Championship event became a "must do" meeting with results being posted nationally. There were special awards for the best designed kart

HISTORY OF SCHOOLS KARTING

and the best built kart which remained as prestigious trophies for many years.

NATIONAL SCHOOLS KARTING ASSOCIATION		
ANNUAL CHAMPIONSHIPS		
RYE HOUSE STADIUM RYE HOUSE STADIUM		
7th JULY 1973		
AWARD WINNERS		
<u>CLASS 100 STIHL</u>		
1st C.GREEN WHITLEY HAY C.T.A.	2nd R.FRYDRYCH CARDINAL BOURNE	3rd B.HILL KING EDWARD VI
<u>CLASS 100 A/C L.P.</u>		
1st N.GREEN MONT. OF ALAMEIN	2nd R.FRYDRYCH CARDINAL BOURNE	3rd P.GAY CARDINAL BOURNE
<u>CLASS 100 A/C HP</u>		
1st D.THOMPSON WILLINGTON	2nd N.GREEN MONT. OF ALAMEIN	3rd J.ELLIOT WILLINGTON
<u>CLASS 210 G/BOX</u>		
1st D.ELLIS COVE	2nd M.WATSON KING EDWARD VI.	3rd M.L.HARVEY NETTESWELL
<u>CLASS 100 ROTARY</u>		
1st N.TODD KING EDWARD VI.	2nd R.KINGSBURY CARDINAL BOURNE	3rd J.GRISLEY ALLEYNES
<u>THE BP TROPHY FOR THE MOST SPORTING EFFORT OF THE DAY</u>		
		P.VELITCH, STEDWARDS
<u>THE BP TROPHY FOR THE BEST SCHOOL BUILT KART</u>		
		KING EDWARD VI.
<u>THE BEST SCHOOL DESIGNED KART</u>		
		HERONSWOOD
<u>THE EVENING POST AND ECHO AWARD</u>		
		D.KING, TURNFORD

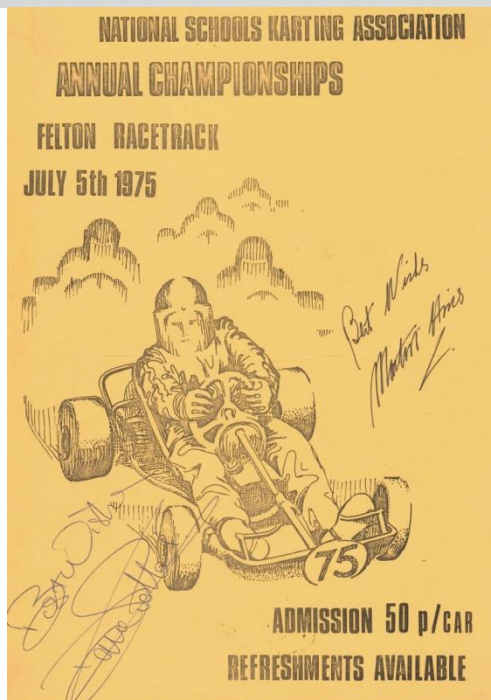

Kart building courses were organised to encourage schools to get involved - Build a rolling chassis and you were given an engine.

Experimentation in kart design was heavily encouraged leading to the design and

building of karts such as Hertskart, Plykart, Monokart, NatSKA 100, Nifty Fifty and Trikart. Some of these designs were made into plan books and spread throughout the country to encourage building.

The karts in use were:

- The Hertskart-1976 which had a rectangular tube chassis and a 50cc ariel engine.



- Plykart - this was a Plywood flat chassis with square tube subframes 100cc Stihl engine.
- Monokart - was a plykart with plywood monocoque upper body and steel subframes powered by a 100cc Stihl engine. Monokart 2 - monocoque filled with expanding foam.
- Natska 100 - this was a 25mm round tube frame with minimum bends powered by a 100cc Stihl engine.
- Nifty Fifty - aluminium central spine chassis with homemade disc brakes using bicycle callipers. It was very light weight, and was powered by a 50cc ariel engine.
- Trikart -this was a 3 wheeled square tube chassis powered by a 50cc ariel engine.

HISTORY OF SCHOOLS KARTING

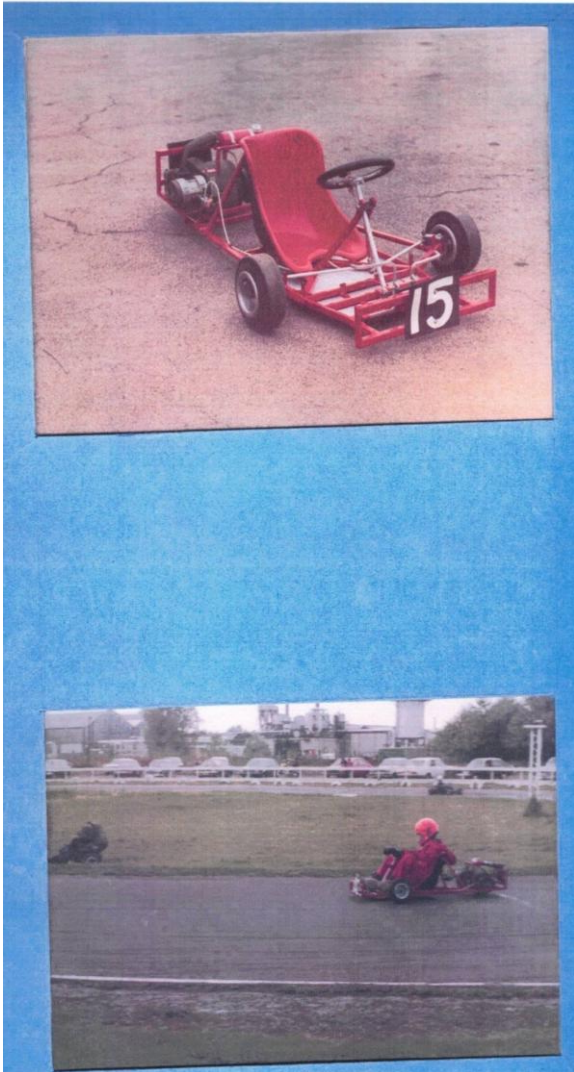

Many more “one offs” were designed and built by schools kart clubs, some successful and some not. At Heronswood school in Hertfordshire (the home school of Colin Fenwick), kart design and building was given a slot on the curriculum for students who were not destined for O levels (the forerunners of GCSEs). During a two year course small groups of kids built (and tested) karts and then presented them to visiting examiners.

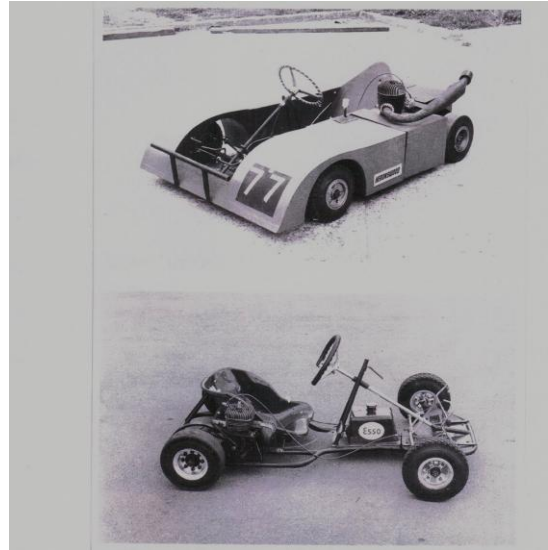

Engines used at this time were often taken from motorbikes with Yamaha FS1E 50cc, Honda H100 and Yamaha RS 100 cc (with the gearbox sawn off!) used along with Stihl 100cc and Solo 60cc chainsaw engines that became the backbone of NatSKA. The FS1E became popular as it could be used in 2 classes of racing, as a 4 speed gearbox and as a direct drive locked in gear.

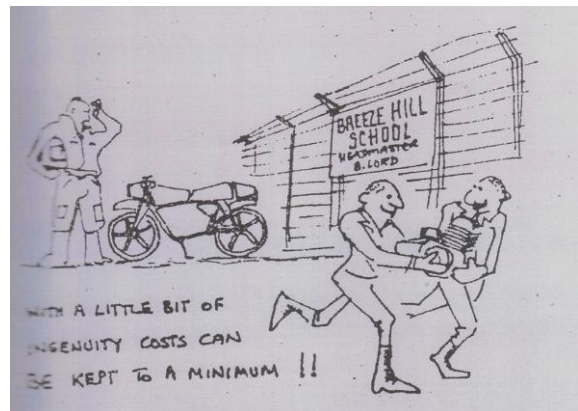

(Note: Breeze Hill School was a regular at NatSKA meetings with Brian Lord going on to become a regular Clerk of the Course)

Herts Karting Association grows to around 13 schools with race meetings at Rye House leading to the annual Herts championships. Offshoots leading from karting included hovercraft building, off road motorbike building, bicycle design innovation and testing and motorised scooter building - all

HISTORY OF SCHOOLS KARTING

were presented as extracurricular competitions.

Interest from other counties leads to national spread of karting courses with lectures etc in training colleges. Loughborough summer school, Shoreditch College (now Brunel University) and other teacher training colleges had visits, presentations and practical driving sessions as well as workshop building.

Videos are made on building karts in school leading to the writing of The NatSKA Guide to Karts and Karting in 1984 written by Brian Lord (Breezehill School, Oldham), Colin Fenwick (Heronswood School, Herts) and Ian Paddy (Hull Grammar School) and supported by Castrol UK. This book was spread through schools and public libraries throughout the country.

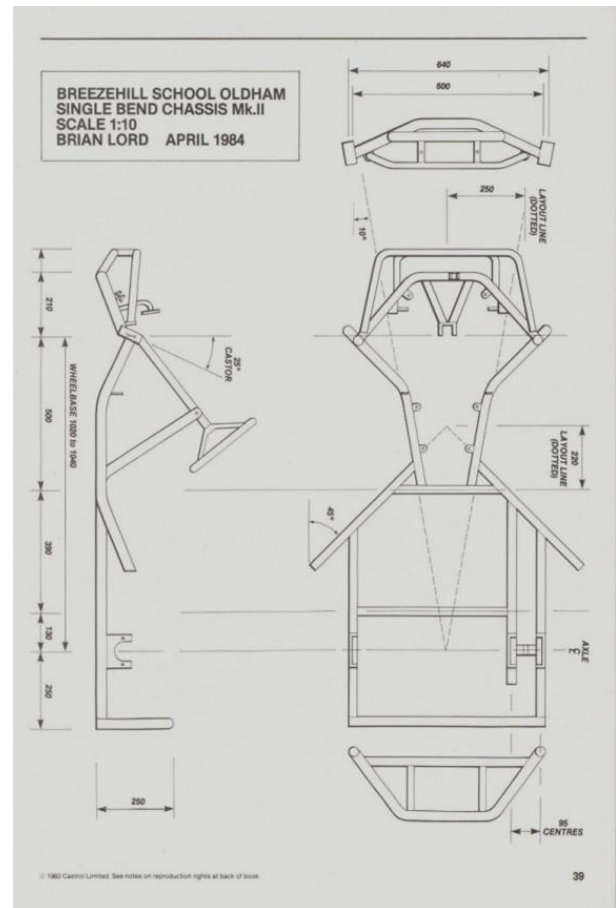
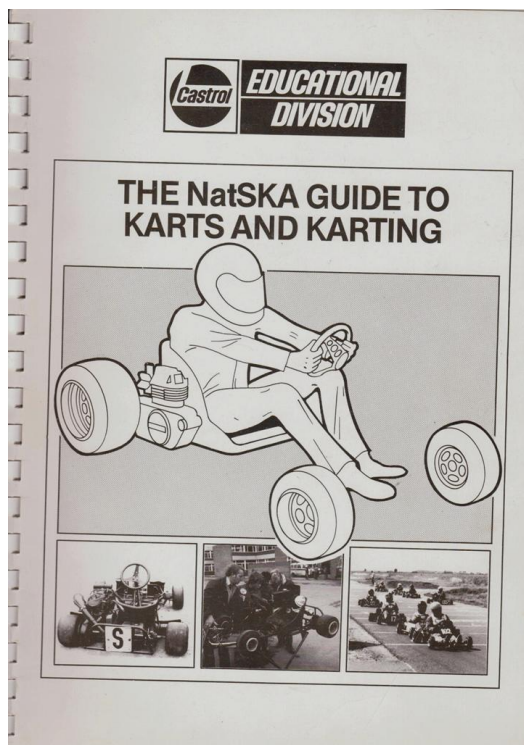

At this time NatSKA ran 9 classes of racing based on engine type ranging from 50cc moped type, 50cc gearbox, 100cc low power, 100cc high power, 100cc rotary valve and 125cc gearbox.

Sponsorship interest from Castrol also led to "Castrol Create a Kart", a national competition to design, build and race a school built kart. This was held at Donington and was judged on criteria such as design innovation of whole kart and/or elements of a kart (braking systems etc), quality of craftsmanship and finish and track performance.

Other interesting developments happened during this time with TV show "Jim'll Fix it" at Rye House seeing Graham Hill Racing a NatSKA 100 against school drivers from Herts schools.

HISTORY OF SCHOOLS KARTING



Two teachers in the midlands (designers of Nifty Fifty) set up Slick, an in house magazine for NatSKA, with a cover star called Lidia Toolbox, an engineer called Buster Conrod and Edited by Hackit and Weld.

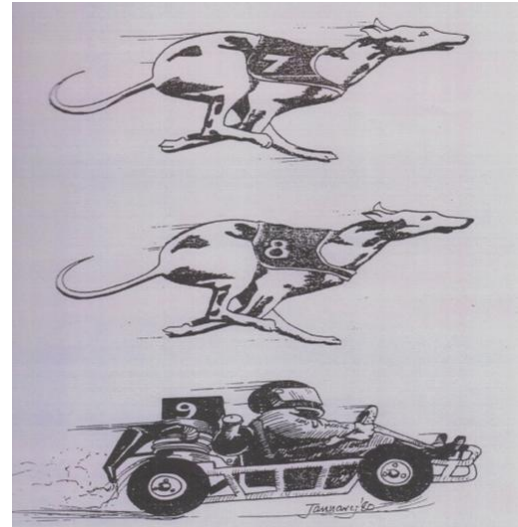

Magpie, a children's Saturday morning programme also featured schools karts at Rye House.

Three time Formula 1 World Champion Jackie Stewart drives a school kart around Rye House (very quickly!) and becomes NatSKA president.

Most importantly NatSKA held a seat on the RAC kart committee for a number of years giving the committee a perspective of “grass roots” karting. (And making one or two deals with the trade representatives along the way!)

The public face of NatSKA is shown clearly in the National Sprint Championships (The Nationals).

From 1979 to 1988 the “Nationals” were sponsored by Esso leading to improved safety, organisation and overall presentation of the day which was reflected in the huge entries. In 1980 NatSKA started the National Enduro Championship event which was held in the spring of each season, however this never became as popular as the sprint event and had a rather patchy history.



Jackie Stewart at Rye House with NatSKA

HISTORY OF SCHOOLS KARTING

LIST OF OFFICIALS - HERTS UNLESS STATED

Steward	- Colin Fenwick, James (Norfolk)
Clerk of the Course	- Brian Lord (Oldham) and Andy Townsend (Cheeshire)
Marshals	- Ex-pupils - Heronswood, King Edward VII, Petersfield
Chief Course Marshal	- Peter Croft, Barry Lockett (North of Tyne) (Notts) and A N Other (Enfield?)
Chief Scrutineer	- Neil Harris
Scrutineers	- John Shearman, Nick Clay, Mel Stephenson (Humberide) Jim Smith (Humberide)
Paddock Marshals	- Rick Gimber, Malcolm Chalmers (E & H) Ernie Peake (Beds)
Lap Scorers	- Three members of Lincs K.C. Elaine Gimber.
Results	- John Barber, Bill Prosser, Bill Waters
Starter	- Lee Bailey, Mike Dixon and/or Terry Humphries (Berks)
Pit Gates	- Jim Hardy and Terry Radford(Notts)
V.I.P. Organizers	- Jim MacGregor (North of Tyne) John Hill (Leics)
Secretary of Meeting	- Ian Cousins
Race Control	- Geoff Hitchings (Hillingdon) Harold Neale (Norfolk)
Gate Personnel	- Volunteers
Design Competition Judges	- Chairman, Ian Paddy (Humberide) Committee, Barry Lockett, John Hill and Brian Lord
Photographer	- As arranged.
First Aid	- St John's Ambulance Brigade

Written by

Colin Fenwick and Jim Hardy

Huge thanks to them both for their time and effort in pulling this together to give you all an insight into NatSKA through the years.....and for ALL of the time that they have dedicated to the kids and families of Barclay School (and in Colin's case Heronswood School before he moved to Barclay!)

Officials at the 1982 Nationals at Fulbeck

Can you spot some familiar names!?



39 years on....but the same days of the year! Our Nationals 1982 / 2021

Next karting



DRIVER SPONSORSHIP PROGRAMME

£2,000 + VAT

PUTTING YOURSELF IN THE DRIVING SEAT ON THE TRACK AND OFF IT.

This programme is aimed at drivers who want to create a career in the world of motorsport, who want to move up the ranks and race at the highest level. From a young age a driver's focus is to improve their physical, mental and technical skills so that they can win races and championships. Luckily at the start they can solely focus on these areas as their family will foot the bills associated, but what happens when you reach a level where this is no longer possible?

The Next Level Motorsport Driver Sponsorship Programme will evaluate your current position in the market, create and adapt a position for you and give you the techniques to convert your own sponsorship deals for the years to come, as you progress through your own successful racing career.

INCLUDED IN THE PROGRAMME:



EVALUATION OF CURRENT POSITION

A review of the driver's racing experience and career so far, to help us understand how to plan towards your ambitions and goals.



DRIVER BRANDING

We will work with the driver to create a new brand identity to be used across marketing materials and online channels.



BUSINESS MARKETING MATERIALS

To be used to get your brand and product across, showcasing the driver in a professional manner.



DRIVER & FAMILY EDUCATION

A seminar designed to transform the traditional outlook on sponsorship into a business-focused outlook.

NEXT LEVEL
MOTORSPORT

GET IN TOUCH FOR SUPPORT IN SPONSORSHIP, PR, MARKETING AND DESIGN SERVICES FOR MOTORSPORT

>> [INFO@NEXTLEVELMOTORSPORT.COM](mailto:info@nextlevelmotorsport.com)



TUBBECK 10TH APRIL 2021 - CHAMPIONSHIP ROUND 3

The first meeting after lockdown - and the weather was definitely on our side! An early frosty morning turned into a beautiful spring day and we were all eager to get racing again.

Before racing began we held a minutes silence to reflect on the death the day before of Prince Philip Duke of Edinburgh, the President in Chief of the British Racing Drivers' Club....and then it was down to business.

The officials of the meeting were all concerned that they might be "a bit rusty" given the length of time since our last meeting - but given all of the preparation that they had put into the meeting, there wasn't any "rust" visible!



To summarise the day - first of all our "low powered" classes

Our **Cadet classes** were dominated by Robbie Smith (AMS) (C4) and Archie Robinson (Stoke) (C1) - Robbie taking 3 wins out of the four heats in his class, and Archie winning all 4 heats overall and setting the fastest lap times of the day.

In **Class 11 Junior Fourstroke**, it was very close all day with Nathan Walker (St Michael's) taking the first heat win very

closely followed by eventual overall winner Lachlan Bott (Tarpoley). Behind them the racing is also very close with Alfie Atmore (Tarpoley) and Harry Leadbetter (St Michaels) very much in touch with the leaders. To top off his trophy winning day, Lachlan Bott also produced the fastest lap of the day in heat 3!

In **Class 10** James Hunting (Phoenix) was top of the standings all day - four heat wins to his name, demonstrating the consistency required.

In **Class 12**, a battenburg flag cost three drivers strong race results and ultimately affected their day as, but for that one of them would have taken the overall win...it's extremely difficult to come back from a visit to the Clerks office. At the end of the day, the overall winner and most consistent driver, taking 2 heat wins and a 3rd place was Faith Hunting (Phoenix)...a good job to balance up the family trophy cabinet with brother James!



In **Class 14 restricted TKM**, the run away winner was Scott Hayward (Bexley) three heat wins and a third place giving him an unassailable lead on the day. Behind him Jamie Leadbetter (St Michael's) proved to be the most consistent of his rivals scores of



FULBECK 10TH APRIL 2021 - CHAMPIONSHIP ROUND 3

2,4,0,3 and an overall score of 5 points confirming him in second place.

...and on to the High Power Classes...

In **Class 7 Junior TKM** in spite of the very very close racing all day between Alexander Arnold (Kingham Hill) and Leo Crabtree (St Michael's), Alexander took 3 wins out of 3 in the first three heats meaning that he had the job done. Leo taking 3 second places and a heat win meant that none of their rivals could catch him either - trophies for the day sorted!

In our historic **Class 8** event, Samuel Forbes demonstrated the engineering skill to keep his beautiful kart going all day and secured 4 heat wins.

In **Class 15 Junior Rotax**, Dan Jones (AMS) was once again supreme - four heat wins, and the fastest lap of the day demonstrating to his rivals the speed and consistency that they will need to achieve this season to beat him....closest to him at Fulbeck was Henry Wardell (Bexley) - he took all four second places to earn him the title of chief rival!

NatSKA - It's about Kids in Karts!



Novices of the meeting

Our keen on circuit observers had their eyes on the novices all day - watching out for safe manoeuvring around fellow novices, good lines in corners and general speed and improvement....

Novice of the day in the cadet class was once again Ethan Grundy (AMS) good consistency gave him a slight edge on the others on this occasion.

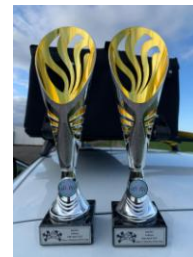

In **Class 11 Novice** Tom Ratcliffe (Quinton House) on his third NatSKA outing demonstrated good skills in overtaking others and good speed overall - watch out for him at Whilton Mill when he will hopefully be completing his novice practice requirements.

In **Class 14N** debutant Adriel Ngwa (Quinton House) also caught the eye of the observers - he will definitely be one to watch at the next few race meetings!



...and that's a chequered flag from Fulbeck!



WHELTON MILL 3RD MAY 2021

CHAMPIONSHIP ROUND 4

So to sum up the day in one word?



...and I think it is fair to say...that's an UNDERSTATEMENT! Not only was it wet...it was also bitterly cold.....but the drivers still enjoyed themselves!

To summarise the day - first of all our "low powered" classes

Our **Cadet classes** were dominated by Robbie Smith (AMS) (C4) and Archie Robinson (Stoke) (C1) - Robbie taking 2nd place in the first heat, and then following it up by winning for the rest of the day! Max Scharfegger took the first heat, and then followed Robbie home all day to take 2nd place overall. Archie had a very similar day to Robbie....3 heats out of 4 for him meant he took home the big trophy!

In **Class 11 Junior Fourstroke**, Fulbeck winners Lachlan Bott (Tarpoley) was, once again, peerless....he took all four heat wins in very challenging conditions. Behind him Harry Hurst (Barnwell) had a fantastic day...this was his last time racing from the back of the grid...what a tremendous series of results for him! His scores of 6,3,2,4 gave

him just 9 points overall to claim 2nd place! Behind Harry it was nip and tuck all day between Caitlin Scharfegger (AMS) and Oliver Livesey (St Michaels)...the two finishing on the same score, with only the dropped score separating the two...on this occasion Caitlin taking 3rd place.



In **Class 10** Abbie Mills (Tarpoley) demonstrated that consistency pays off....the only difference between her and James Hunting was James' non start in one of the heats

In **Class 12**, there was no question who the winner was. Dougal Hamilton-Smith (Kingham Hill) had the worst result of his day in heat 1...from then on, the others trailed in behind him....he's clearly a driver for wet weather. First heat winner David Otero took second place overall after taking 2nd & 3rd places in heats 3 and 4.

In **Class 14 restricted TKM**, the runaway winner was, once again, Scott Hayward (Bexley) who took three heat wins and a third place to mean that he couldn't be



WHELTON MILL 3RD MAY 2021 =

CHAMPIONSHIP ROUND 4

beaten. Behind him (and pictured here with his “Ace Mechanic” mum, Louise) Ben Hurrell (Quinton House) had a good day...he took the remaining heat win and two second place finishes to mean he took 2nd place from his teammate Will Wood.



...and on to the High Power Classes...

In **Class 7 Junior TKM** Alexander Arnold (Kingham Hill) took 3 wins out of 3 in the first three heats meaning that he had the job done. Behind Alexander, Joseph Booth (Tarpoley) took 3 second places and a heat win, to edge out Samantha Seward (Kingham Hill). Trophies for the day sorted!

In **Class 15 Junior Rotax**, Dan Jones (AMS) was once again supreme - although on this occasion his rivals were much closer! On this occasion three different drivers took heat wins, Dan taking two and a second place on his way to the biggest trophy...closely followed by Ewan Sime (Tarpoley) and Joseph Habershon (Barclay)

In **Class 13** - Tyler Wannerton took all four heat wins!

NatSKA - Race your mates!



Novices of the meeting

Our keen on circuit observers had their eyes on the novices all day - especially in view of the extremely challenging weather conditions!

Novice of the day in the cadet class was once again Cayetano Dare Ruiz (Kingham Hill).

In **Class 11 Novice** George Spence (Tarpoley) demonstrated good skills to catch the eye of our Novice Observing Team.

In **Class 14N** Harry Bloor (Quinton House) also gave the observers some good skills to watch, meaning that, once again the Quinton House team took home a Novice of the Day trophy - their trophy cabinet might need an extension before too much longer!





SHENINGTON 8TH MAY 2021

CHAMPIONSHIP ROUNDS

It had been 33 YEARS since NatSKA had last visited Shenington and so we were very excited to be going back to Banbury....suffice to say, that even some of the team leaders weren't BORN the last time we had been there!

Once again the weather was LESS than kind....but as always the drivers still enjoyed themselves!

To start with, for Shenington, we were really pleased to see entries in what is perhaps our oldest class...Class 8 Rotary / Reed / Piston Ported.



Both drivers in the class (Julian Sanders and Samuel Forbes) had good days and showed real speed and consistency to pass the Class 7s. Overall Julian took the win with three heat wins...



In **Class 7 Junior TKM** Alexander Arnold (Kingham Hill) once again took the overall win - this time he had to run in all four heats to get the job done though! Samantha Seward (Kingham Hill) took the first heat win and followed that up with three second place runs. A good day's work!

In **Class 15 Junior Rotax**, once again there was some superb and close racing....but when all of the scores were taken into account Dan Jones (AMS) took the overall win once again! On this occasion Max Homfray-Cooper and James Habershon (both from Barclay) were Dan's main rivals. James started the day well taking the opening heat win but a penalty in the third heat (with the score having to be kept overall) relegated him to third place. Max was the more consistent of the two (3,2,2,2) to take second place overall.

In **Class 13** - Tyler Wannerton took all four heat wins!



SHENINGTON 8TH MAY 2021

CHAMPIONSHIP ROUNDS

Our **Cadet** classes were dominated by Max Scharfegger (AMS) (C4) and Archie Robinson (Stoke) (C1) - Max taking three heat wins and a 2nd place in the final heat, he was closely followed home all day by team mate and Whilton Mill winner, Robbie Smith. Archie had a very super day taking all four heat wins!

In **Class 11 Junior Fourstroke**, Lachlan Bott (Tarpoley) made it 3 wins out of 3 since the postlockdown re-start... Behind him team mate Alfie Atmore had another good day - he took the first heat win and followed it up with counting scores of a 3rd & a 2nd. The podium (if we could have one!) would have been completed by Nathan Walker (St Michael's) who also had a good consistent day.

In **Class 10** James Hunting back to top form - he took all four heat wins!

In **Class 12**, there was no question who the winner was. Alfie Heaps (Thomas Alleyne Academy) overcame huge hurdles just to get to Shenington (after the family car broke down on the way)...but the determination to get to the circuit paid off and there was DEFINITELY NO STOPPING HIM...he took all 4 heat wins, meaning the result was never in question. Behind him the racing between Alex Fallart (Barnwell) [3,2,2,7] and Whilton Mill winner Dougal Hamilton-Smith (Kingham Hill) [4,3,3,7] was very close!

In **Class 14 restricted TKM**, Harrison Hine (Tarpoley) brought the running streak of Scott Hayward (Bexley) to an end. Harrison

took all four heat wins on the day to take home the big trophy! Scott kept up his consistency though - he took second place overall, and was followed onto the "podium" by Quinton House's Ben Hurrell

Novices of the meeting

Our keen on circuit observers had their eyes on the novices all day - especially in view of the extremely challenging weather conditions!

In **Class 11 Novice** Ben Seward (Kingham Hill) demonstrated good skills to catch the eye of our Novice Observing Team.

In **Class 14 Novice** Conner Young (Bexley) also gave the observers some good skills to watch.

Quinton House's Harry Wilch reminds the NatSKA team...it's all about "Kids in Karts"





CAMBERTON 29TH MAY 2021

CHAMPIONSHIP ROUND 6

.....and FINALLY THE SUN CAME OUT!

A gorgeous day for racing...and some absolutely fantastic on track battles to report on!

...and this is what NatSKA is ALL about!

Quinton House team celebrating a sunny day!



Stuart gathers the grid together for a "mini-briefing"



In Class 15 Junior Rotax, there was some superb racing....and on this occasion the final result was determined by the top two drivers' fastest lap times...the difference between the two? Just 0.49 of a second!

Now that's close....blink and you would miss the gap that separated 1st and 2nd place.

Dan Jones (AMS) started the day with two heat wins....his rival Max Homfray-Cooper started the day with a DNF...the roles then reversed and in the 3rd heat Dan had a DNF and Max took the last two heat wins. Both had a 2nd place as their other counting score...meaning it went down to fastest laps...Dan 27.53 compared to Max 28.02....we hope that the season continues like this!



In Class 13 - Tyler Wannerton took all four heat wins again!

In Class 11 Junior Fourstroke, Lachlan Bott (Tarpoley) continued his winning streak... he took three heat wins and a second gave him an uncatchable lead on the day. Behind Lachlan it was a very close battle between team mates Joshua Behan [7pts] (18,3,2,2) and Deven Trotman [8pts] (3,0,13,5) (both Kingham Hill) - only one point difference between them at the end of the day and



CAMBERLEY 29TH MAY 2021

CHAMPIONSHIP ROUND 6

some superb racing. Harry Hurst from Barnwell once again took home a trophy - this time 4th place after consistent scoring gave him 11 points overall. Alfie Atmore (Tarpорley) gave us all a scare after an incident in the second heat - very pleased to report that after being checked over at the local hospital, Alfie returned bruised and gutted to miss out on valuable championship points!



In **Class 10** Abbie Mills took all four heat wins!



In **Class 12**, there was no question who the winner was. Alex Fallart (Thomas Alleyne Academy) took three heat wins as his scoring results meaning no-one else could catch him on the day. As in Class 11 it was very close behind him - Dougal Hamilton-Smith (Kingham Hill) battling it out all day with Alfie Heaps (Thomas Alleyne). There was only a point between them when the scores were tallied up!

In **Class 14** restricted TKM, Scott Hayward (Bexley) was back on top form, and back on the metaphorical top step of the podium. He took two heat wins and a second place as his counting scores. Behind Scott, Quinton House's Ben Hurrell took his first ever heat win....we bet it was a happy car on the way back to Northamptonshire! Another driver taking a heat win was Jamie Leadbetter from St Michael's, underlining the point that this is a VERY close class at the moment!

On this day, our **Cadet** classes were dominated by Robbie Smith (AMS) (C4) and Archie Robinson (Stoke) (C1) - Robbie took all four heat wins in Class 4. Archie also had a super day taking all four heat wins!



Robbie Smith (AMS - Class 4)



CAMBERLEY 29TH MAY 2021

CHAMPIONSHIP ROUND 6

...and Robbie's Mechanic - hard at work!



In Class 7 TKM, Alexander Arnold (Kingham Hill) took the first three heat wins of the day, and decided to sit out the final race, to claim the overall victory. Behind him Molly Nicolas-Biles (Thomas Alleyne) took the final heat win and proved to be Alexander's most consistent rival.....and looking at the result 4 of the top 5 places were claimed by girls (Bethany Livesey, Samantha Seward and Molly Heaps completing the top five!). Watch out boys....the girls will claim that top spot soon!

(Note: no-one sent me any photos from this class!)

Novices of the meeting

On this day it was the novices from St Michael's Kart Team who were celebrating - taking home both trophies!

In Class 11 Novice Finley McDonough demonstrated how safely he can drive to catch our observers attention.

In Class 14 Novice Millie Howard showed that the racing grid will definitely be enhanced when this particular bunch of novices move up....it was a very close call between them!

...and my photo correspondent from this class was Finley Roberts (Tarpoley) - he really enjoyed his day and shared this with us!



...and the last word?

Kids...this is the view that you don't get!





FULBECK 12TH JUNE 2021

CHAMPIONSHIP ROUND 7

....and ANOTHER GLORIOUS DAY....both in terms of the weather and the racing!

....in terms of photographs received for the race report? I think that this will just be about Class 11!



As you can see from the photo - it was a VERY FULL GRID of Class 11 & 10 drivers...so it was always going to be interesting racing!

Barnwell's Harry Hurst has grasped very quickly that the best way to drive around a lap is to learn your lines and identify where the marshal posts are (that way you will know if there is an incident ahead!)....here he is learning on a "slow lap" around Fulbeck!



In racing terms in Class 11 it was very much business as usual for Lachlan Bott from Tarporley...he took the win to take his winning streak so far this season to the six rounds of the championship that he has attended....he didn't have it all his own way at Fulbeck though...his teammate Alfie Atmore took two heat wins and but for an incident in heat 3 which meant he had to carry that score he would have been much closer to the top spot.

Thomas Forbes (Barnwell) took 2nd place overall with a combined score of 11 points). Evan Bradley (St Michael's) and Caitlin Scharfegger (AMS) both had good days - at

the end of the day, it was only the dropped score that separated them!

....and if the timing system says that you were the fastest driver of the day in ANY class, then it must be right (yes?).

Tom Strefford (Tarporley) had a day to forget in racing terms...BUT...the system shows that he set by far the fastest lap of the day!!! He'll take that!

Pos	No	Name	Clx	New	Laps	Time (min:sec)	Retired	Best	Drop
1	83	Tom Strefford	C11NatSKA-N	N	4	3:51.03	43.223	4:07	3
2	2	James Kingham Hill	C11NatSKA		3	3:01.00	34.149	03.620	09.89
3	5	Alfie Atmore	C11NatSKA		3	3:04.04	33.212	03.620	09.80
4	66	Thomas Forbes	C11NatSKA		3	3:01.21	34.443	03.900	1:00.21
5	80	Lachlan Bott	C11NatSKA		3	3:04.41	33.845	04.040	1:00.11
6	25	Evan Bradley	C11NatSKA		3	3:02.43	34.212	04.080	1:00.15
7	82	Harry Hurst	C11NatSKA		3	3:04.34	33.808	04.140	1:00.21
8		Dean							Kingham Hill



In Class 10, the battle between James Hunting (Phoenix) and Abbie Mills (Tarporley) resumed - on this day, James took the top spot!

In Class 7 Junior TKM, Alexander Arnold (Kingham Hill) has only been beaten once in the seven championship rounds that have been held...his rivals are undoubtedly getting closer though, and it remains all to play for in the championship standings. Molly Nicolas-Biles (Thomas Alleyne Academy) took 2nd place on the day to cement her place in 2nd place ahead of the Nationals, and on this day Jake Bastable (Stoke) took his



FULBECK 12TH JUNE 2022

CHAMPIONSHIP ROUND

highest finish of the season so far to claim 3rd place overall.

In **Class 13**, Tyler Wannerton (Barclay) looked comfortable racing on the same grid as the **Class 7 / 8s**...and in **Class 8** Julian Sanders showed exactly how fast those **Class 8s** will go when they are given the opportunity!



Classes 14 & 12

In **Class 14 restricted TKM**, Jack Wilch took two heat wins on his way to the **FIRST EVER OVERALL WIN** for team **QUINTON HOUSE**! I think it's fair to say there were celebrations in the paddock for the QH crew at the end of the day! In fact Quinton took 3 of the 4 heats, Jack's team mate Ben Hurrell collected another heat on his way to 3rd place overall.

In 2nd place on this occasion was championship leader Scott Hayward from Bexley...he also took a heat win before being narrowly beaten to the top spot by Jack. I think it's fair to say it is absolutely anybody's Nationals in this grid!

In **Class 12** Alfie Heaps claimed the overall victory - no heat wins, but he demonstrated the importance of consistent

results....three 2nd places giving him a score of 6 points on the day.

His nearest rival on this occasion was Kingham Hill's Dougal Hamilton-Smith who, by virtue of a better dropped score, narrowly pipped Faith Hunting (Phoenix) to 2nd place overall...in the championship Dougal remains at the top, just 6 points ahead of Alex Fallart (Barnwell) who took fourth place overall at Fulbeck.

In **Class 1**, Archie Robinson (Stoke) once again took the top spot from Casey Wannerton (Barclay).

In **Class 4**, Max Scharfegger (AMS) took another overall victory from teammate Robbie Smith...who remains in the lead in the championship!

Class 15



Following Caden Bott and Josh Nevel

In **Class 15**, Dan Jones (AMS) made it six in a row for him confirming his place at the top of the championship ahead of his closest rivals Max Homfray-Cooper (Barclay) and Ewan Sime (Tarpoley). On this occasion Max once again took a heat win, and Ewan had a consistent day ultimately losing out to Andrew King (Barnwell) by virtue of a slightly worse dropped score...it will be all to play for by the time the Nationals comes around!



FULBECK 12TH JUNE 2021

CHAMPIONSHIP ROUND 7

Novice classes



Millie Howard
(Class 14 Novice of the day from the Camberley meeting!)

Our eagle eyed observers always pay particular attention to our Novice classes watching for good lines, safe driving, speed and driving standards. At Fulbeck they weren't disappointed and were happy to nominate:

Finley Roberts (Tarpoley) as the Class 11 novice of the day, Conner Young (Bexley) as Class 14 Novice, and Rowan Slaughter as the class 1 novice!

Parents.....this is what it looks like to be on the front row of the grid at Fulbeck.....we just thought you might like to know !



...and with that, we are moving on to the penultimate round of the 2020-21 season at Bayford Meadows....





BAYFORD MEADOWS 27TH JUNE 2021

CHAMPIONSHIP ROUND B

The lockdown in March had put paid to our first meeting of the year (scheduled for Bayford Meadows), and the circuit owners had really pulled the stops out to find us a date....(and within the same Championship year too, how lucky are we!?)

I think that it's fair to say, after the beautiful weather that we had got used to at Fulbeck and Camberley, we were a bit disappointed by the lack of blue sky (and perhaps even more by the attempts at rain throughout the day...)

BUT - IT DEFINITELY DIDN'T SPOIL THE RACING!

In Class 12 there were three different heat winners...it really is very close racing in this class, and it looks like the Nationals meeting is going to be fascinating!



This photo shows all three heat winners! Karts 7, 19, and 27 (Arthur Hagland, Dougal Hamilton-Smith, and Faith Hunting!).

The overall winner on this day was Dougal - he took 2 heat wins and a second place to give him an overall score of 2 points, in 2nd place was Arthur (4,0,3 his counting results) and in third place was Faith (0,4,4). The Nationals are going to be interesting!

Also in class 12 were brother and sister combo Molly (kart 84) and Alfie Heaps (kart 3) - racing for the last time together on the same grid...I can't imagine how their Mum and Dad cope!



In Class 14, once again the racing was VERY close...but, out in front again with three heat wins was Bexley's Scott Hayward. In second place was Harrison Hine (Tarpoley) - he demonstrated the benefits of good consistency to take two thirds and two second places, giving him a final score of 7 points. In third place was Quinton House driver Ben Hurrell. He had a mixed day with a couple of unlucky incidents - but recovered well in the last heat to take the final win of the day and give him an overall score of 14points.





BAYFORD MEADOWS 27TH JUNE 2021

CHAMPIONSHIP ROUND 8



Class 14 winner - Scott Hayward

In Class 7, Molly Nicolas-Biles (Thomas Alleyne Academy) had a fantastic day - she too took the first three heat wins meaning that her day was done. Second place overall on this occasion went to Bethany Livesey (St Michael's) who had three 2nd places as her scoring results and narrowly taking the 2nd place trophy from Kingham Hill's Samantha Seward by virtue of a better "dropped" score.



Molly enjoyed sharing the circuit with her Thomas Alleyne's team mate (and Class 8 winner) Julian Sanders!

In fact, the whole Thomas Alleyne Academy team looked like they had a fantastic day....



In Class 13, Tyler Wannerton took all four heat wins!

In Class 11, Barnwell's Thomas Forbes was the class of the field - he took 3 heat wins and a second place to give an overall score of 0 points! Tarporley's Alfie Atmore had three 2nd places to confirm his place behind Thomas...it was close in 3rd place, equal on points at the end of the day it meant that the "dropped" score came into play...on this occasion Quinton House driver Tom Ratcliffe "dropped" a 7th place, which meant he edged out Barclay's Warren Kiss who had a 10th place to "lose". It's fair to say though that as Warren had achieved that result while still racing as a novice from the back of the grid, he is definitely ONE TO WATCH!



In Class 10, James Hunting took all four heat wins!



BAYFORD MEADOWS 27TH JUNE 2021

CHAMPIONSHIP ROUND 8

In Class 1 Archie Robinson (Stoke) started the day with a non-finish (but at the same time earned himself some fans from the on-circuit team for the way he dealt with the situation...) from then on we had a storming afternoon taking the remaining 3 heat wins. Casey Wannerton (Barclay) enjoyed another day and took 2nd place.

In Class 4, John Seward (Kingham Hill) took all four heat wins!

In class 15, Dan Jones had another storming day and took the first three heat wins...he then parked the kart in scrutineering...job done.



Novice of the meeting was Alana Arnold from AMS!

....and so...on we go to our 50th Anniversary National Sprint Championships at Fulbeck.

The Championship decider...I hope you all have your calculators handy!



In second place was Bexley's Henry Wardell - his final score was 6points after results of 3,2,2,2. Completing the podium today was Henry's Bexley teammate Hayden Abrahams - he narrowly edged out Tarporley's Daniel Andrews. Overall there was some fantastic racing in this class at this meeting!



I think that it's fair to say that NONE of you want the 2nd of these "autographs" when you go to Fulbeck for the Nationals this time!

Since we resumed racing in April there has been a small group of people working on "Bite Size Briefings".

The aim is to keep you up to date with your knowledge of key safety messages...and make sure that you don't throw good results away because you have forgotten a key point.

The "Training Group" consists of:

- Nicky Clarke - on of our fab Start / Finish team!
- Paul Sirett - a Clerk of the Course!
- Jordan Brown - a team leader and former successful NatSKA driver (Class 15 Champion 2017)
- Maria Bright - former successful NatSKA driver (Class 7 2017) now one of our Social Media Team
- Caroline Wardell - a team leader and one of our Social Media Team

So far, the group have developed the concept of "Team Training Ambassadors" (...every team should have one! - Do you know who yours is? If not...let us know!)and they have also distributed guidance on:

- Battenburg flags;
- White Lines and Kerbs;
- Rolling Laps and Breaking formation;
- Warning flags and Penalties
- and they shared "set up" information for the Sherington meeting

The Team Training Ambassadors' responsibility is to pass on the training / training materials to their teams whenever/however they meet up? They are not expected to be experts on the materials...The role is carried out 'away from track/events'.

If you are interested in joining the Training Group or becoming a Team Training Ambassador, please let us know!

OR...if there is a subject that you are not sure of and would like it to be covered, just drop us a line and we will do our best to sort it out!

CHAMPIONSHIP TABLES - AS THEY STAND!

2020-21 Championship Class 1

Pos	No	SC	Name	R1	R2	R3	R4	R5	R6	R7	R8	R9	Total	To Count
1	1		Archie Robinson	100	100	100	100	100	100	100	100		800	600
2	5		Casey Wannerton	98	98		98	98	98	98	98		686	588

2020-21 Championship Class 4

Pos	No	Name	R1	R2	R3	R4	R5	R6	R7	R8	R9	Total	To Count
1	03	Robbie Smith	0	100	100	100	98	100	98			596	596
2	02	John Seward	0	98	96	96	96	98		100		584	584
3	11	Joseph Smith		96	94	94	90		0			374	374
4	19	Ethan Grundy					94	96	96			286	286
5	22	Cayetano Dare ruiz					92	94				186	186

2020-21 Championship Class 7

Pos	No	SC	Name	R1	R2	R3	R4	R5	R6	R7	R8	R9	Total	To Count
1	93		Alexander Arnold	100	96	100	100	100	100	100			696	600
2	3		Molly Nicolas-biles	96	98	96	94	88	98	98	100		768	586
3	2		Samantha Seward	92	92	90	96	98	94	94	96		752	570
4	19		Bethany Livesey	0	90	94	92	94	96	92	98		656	566
5	55		Jake Bastable	94	94		90		90	96			464	464
6	36	158 N	Ben Johnson			88	88			90	94		360	360
7	50		Matthew Mather	90		92		96					278	278

2020-21 Championship Class 8

Pos	No	SC	Name	R1	R2	R3	R4	R5	R6	R7	R8	R9	Total	To Count
1	51		Julian Sanders					100	100	100	100		400	400
2	53		Samuel Forbes	100		100		98					298	298

2020-21 Championship Class 10

Pos	No	SC	Name	R1	R2	R3	R4	R5	R6	R7	R8	R9	Total	To Count
1	71		James Hunting	100		100	98	100		100	100		598	598
2	73		Abbie Mills	98		98	100	98	100	98			592	592

CHAMPIONSHIP TABLES - AS THEY STAND!

2020-21 Championship Class 11

Pos	No	SC	Name	R1	R2	R3	R4	R5	R6	R7	R8	R9	Total	To Count
1	85		Lachlan Bott	100		100	100	100	100	100			600	600
2	5		Alfie Atmore		100	94	92	98	62	84	98		628	566
3	25		Evan Bradley	94		88	88	94	84	96	90		634	550
4	66		Thomas Forbes			80	84	88	90	98	100		540	540
5	45		Oliver Livesey	0	90	82	94	90	82	88	88		614	532
6	92		Harry Hurst				98	82	94	92	86		452	452
7	9		Noah Webb			78	76	72	70	72	78		446	446
8	95		Leah Rowland		92		78	84	68	76			398	398
9	2		Joshua Behan		94	92			98	82			366	366
10	88		Tom Ratcliffe					86	92	80	96		354	354
11	7		Oliver Costello				68	68	66	56	84		342	342
12	68		James Thompson				86	76	86	90			338	338
13	96		Alex Favro				80	78	72	86			316	316
14	33		Laurie Wessel			84	72	62	78				296	296
15	18		Matthew Pepe					66	60	68	80		274	274
16	20		Peter Nunes-randall						74	60	82		216	216
17	56		Nathan Tyler						64	54	76		194	194
18	1	N	Warren Kiss							74	94		168	168
19	77	N	Andrew Wilman						76	62			138	138
20	93	N	Tom Strefford						58	48			106	106

2020-21 Championship Class 12

Pos	No	SC	Name	R1	R2	R3	R4	R5	R6	R7	R8	R9	Total	To Count
1	19		Dougal Hamilton-smith	96	100	92	100	96	98	98	100		780	592
2	13		Alex Fallart	98	92	96	96	98	100	94	94		768	582
3	3		Alfie Heaps	86	84	98	94	100	96	100	88		746	576
4	27		Faith Hunting	92		100	92	94		96	96		570	570
5	91		Nathan Walker	96	96	98		96	92		84		562	562
6	84		Molly Heaps	94	94	94	88	92	90	92	90		734	556
7	38		David Otero	100	82		98		94	90	92		556	556
8	7		Arthur Hagland	88	86		86	88	88	82	98		616	534
9	8		Evan Handley	98	98		74	74	88	78	86		596	522
10	12		Harley Grayling	92	88		70	70	80	70	82		552	482
11	17		Francesca Beretta	84	90		90	90		88			442	442
12	8		Joshua Potts	82	80				84	84	80		410	410
13	90		Harry Leadbetter			96	82		86	86			350	350

2020-21 Championship Class 13

Pos	No	SC	Name	R1	R2	R3	R4	R5	R6	R7	R8	R9	Total	To Count
1	13		Tyler Wannerton	100	100		100	100	100	100	100		700	600

**2020-21 Championship
Class 14**

Pos	No	SC	Name	R1	R2	R3	R4	R5	R6	R7	R8	R9	Total	To Count
1	31		Scott Hayward		100	100	100	98	100	98	100		696	598
2	67		Ben Hurrell	96	96	94	98	96	98	96	96		770	580
3	07		Harrison Hine	100		96	90	100	88	92	98		664	576
4	08		Jamie Leadbetter	92	98	98	86	94	96	84			648	564
5	28		Cyril Smith	98	94	88	94	88	84	86	88		720	550
6	05		Oliver Kirk-roe	94		92	92	92	90	88			548	548
7	29		Charlie Phillips	0		90	84	86	86	80	90		516	516
8	58		Jack Wilch				88	90	94	100	78		450	450
9	24		Will Wood				96	84	92	94	80		446	446
11	54	N	Harry Wilch							82	82		164	164

**2020-21 Championship
Class 15**

Pos	No	SC	Name	R1	R2	R3	R4	R5	R6	R7	R8	R9	Total	To Count
1	1		Dan Jones	0	100	100	100	100	100	100	100		700	600
2	4		Max Homfray-cooper	100	92		94	98	98	98	86		666	580
3	5		Ewan Sime	92		96	98	90	90	94	88		648	560
4	18		Andrew King	94	76	92	90	94	84	96	92		718	558
5	7		Henry Wardell	0	88	98		88	94	92	98		558	558
6	9		Harry Parr		90	90	76	82	86	90	90		604	528
7	8		Hayden Abrahams		96	76	78	70	76	88	96		580	510
8	32		Caden Bott	86		88	82	74	92	84			506	506
9	3		Josh Neve	0	84		68	92	88	86	82		500	500
10	29		Cameron Bott	84		86	88	86	78	76			498	498
11	14		Joe Webb	80	98	80	70	80	80	80	76		644	498
12	20		Katie Hodgkinson	88	80		84	72	72	78	84		558	486
13	71		Tom Rayer	82	78	84		76	74		80		474	474
14	10	162	Joseph Wardell	0	82	78	74		70	72	78		454	454
15	35		Matthew Lewin	96		82	86	84	68				416	416
16	34		Daniel Andrews	90			80	78		74	94		416	416
17	33		James Habershon	98	86		96	96					376	376
18	73	N	Alex Byles			94	72		82	82			330	330

1971 - 2021
50th Anniversary Nationals
 Fulbeck
 9th - 11 July 2021

On Sunday afternoon, one very worthy driver will be the recipient of

The Martin Speed Trophy.

This trophy is awarded in memory of Martin, a former NatSKA racer and team leader, and the son of our NatSKA stalwarts' Dave & Carol. Martin very, very sadly died after a short illness in 2018.

He is hugely missed by all who knew him in his life....but particularly by those who were "less fortunate" than himself, but who shared his passion for motorsport.

Martin gave his time generously and provided the help that allowed many, many young people to participate in karting....without him and his parents many in the school team (Edmonton) quite simply would not have been able to take to the circuit and enjoy our sport.

Martin was taken far, far, far too soon....but during his time on this planet he achieved far more than many of those who live to be much, much older. Quite simply he was inspirational. The paddock is a sad place without him.

If you like, this trophy is awarded to the "sportsmen of the year" - a person who loves their racing as much as Martin did, and always finishes with a smile on their face (irrespective of the results).

This will be the 2nd time that this trophy has been awarded - and is indeed a huge honour to be the recipient....

